

WARING COMMERCIAL

UK Medium Duty Bar Blender
with Electronic Keypad, 99 Sec. Countdown
Timer and 48 oz. Copolyester Container

BB340K

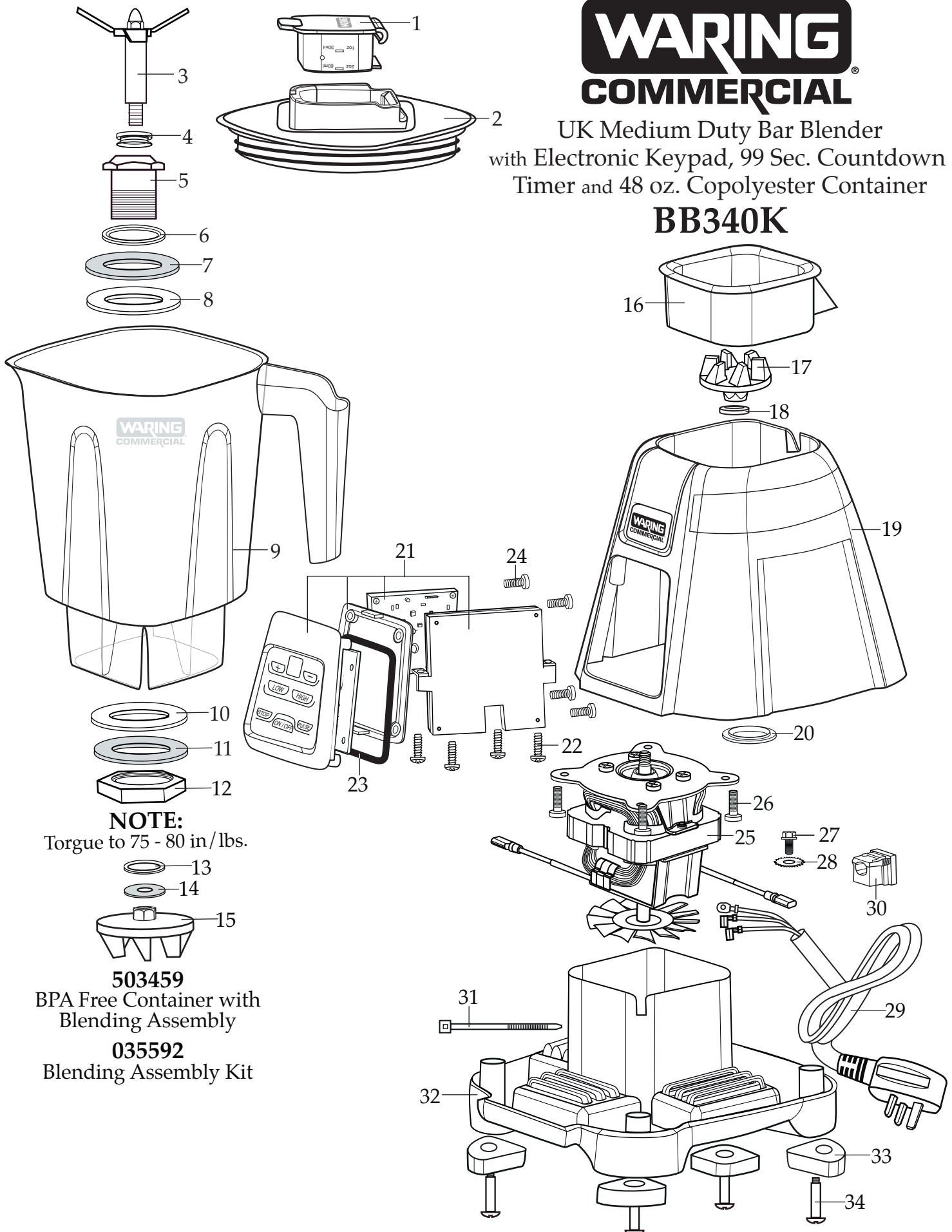

NOTE:

Torque to 75 - 80 in./lbs.

503459
BPA Free Container with
Blending Assembly
035592
Blending Assembly Kit

Illustration #	Part #	Description
1	035153	Jar Cover Lid
2	033625-M	Monoprene Jar Cover
3	503444	Blade Assembly
4	027716	V Seal
5	503458	Bearing Holder/Seal Assembly
6	009724	Nylon Flat Washer
7	003537	Stainless Steel Washer
8	003509	Neoprene Washer (rubber)
9	033626	48 oz. Eastman BPA Free Copolyester Container
10	003509	Neoprene Washer (rubber)
11	003537	Stainless Steel Washer
12	034156	Bearing Holder Nut
13	003526	Phenolic Washer
14	035048	Flat Stainless Steel Washer
15	032453	Coupling
16	033623	Jar Pad
17	032453	Coupling
18	035756	Stainless Steel Cap Washer
19	033616	Top Housing
20	026269	Upper Motor Mount
21	035417	PCB Control Panel
22	033526	Screw (4 required)
23	033737	O Ring
24	026267	Screw (4 required)
25	035170	230 volt Chiaphua Motor
26	032611	Screw (4 required)
27	027278	Ground Screw (2 required)
28	002943	Washer (3 required)
29	503491	Cordset Assembly
30	033619	Strain Relief

Illustration #	Part #	Description
31	013731	Wire Tie (2 required)
32	035282	Bottom Housing
33	035287	Foot (4 required)
34	035260	Screw (4 required)

