

MODEL 1200



004.12.00001

MODEL 1200

DESCRIPTION : STEEL STRUCTURE AND COVERS

ITEM CODE : -

PART ID	DESCRIPTION	QTY
001.12.00021	COVER - TOP	1
001.00.00097	INOX TAPED SCREW M5X25	2
003.12.00004	CONTROL PANEL - COMPLETE	1
003.00.00242	HEX INOX SCREW M6x12 (TOP COVER SUPPORT)	2
003.12.00004	DISPLAY PANEL COMPLETE MOD1200	1
001.12.00019	DOOR COMPLETE MOD1200	1
001.12.00020	COVER - FRONT	1
001.12.00022	COVER - SIDES DX AND SX	2
003.00.00042	HEX BOLT (TOP-SIDE COVERS SUPPORT)	6
001.00.00204	LOCK WASHER (TOP-SIDE COVERS SUPPORT)	6
003.00.00516	WASHER (TOP-SIDE COVERS SUPPORT)	6
001.00.00262	INOX TAPED SCREW M5x16 (SIDE COVERS SUPPORT)	4

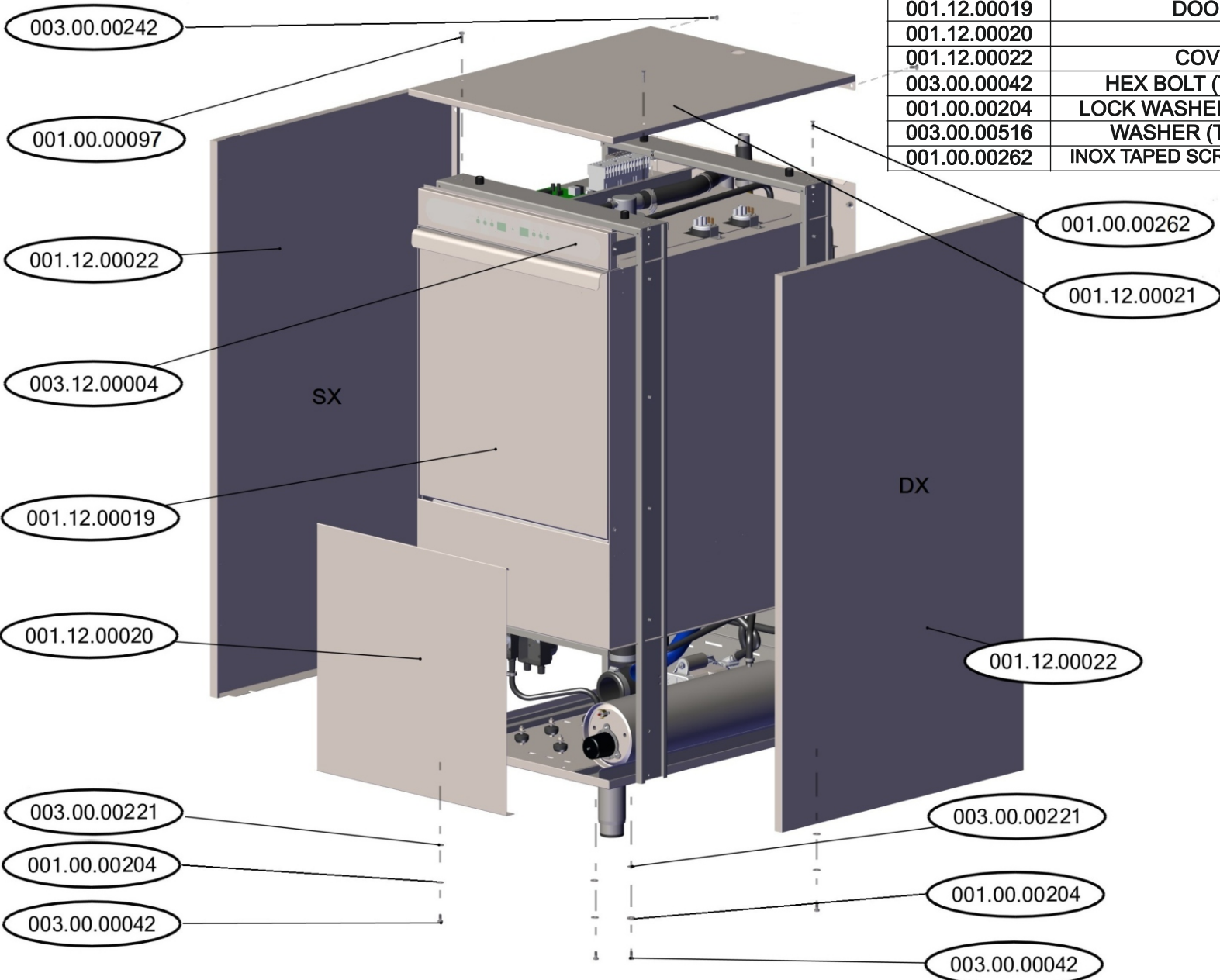

MODEL 1200

DESCRIPTION : STEEL STRUCTURE AND COVERS

ITEM CODE : -

PART ID	DESCRIPTION	QTY
001.12.00023	COVER - BACK - TOP	1
003.00.00242	HEX INOX SCREW M6x12 (BACK-TOP COVER)	6
001.12.00029	COVER - BACK - BOTTOM	1
001.00.00280	WASHER INOX D4x10	4
003.00.00278	HEX BOLT M4x10	4

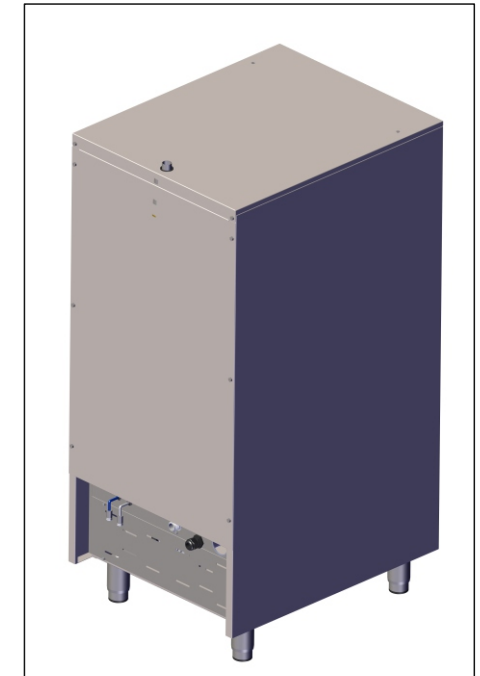
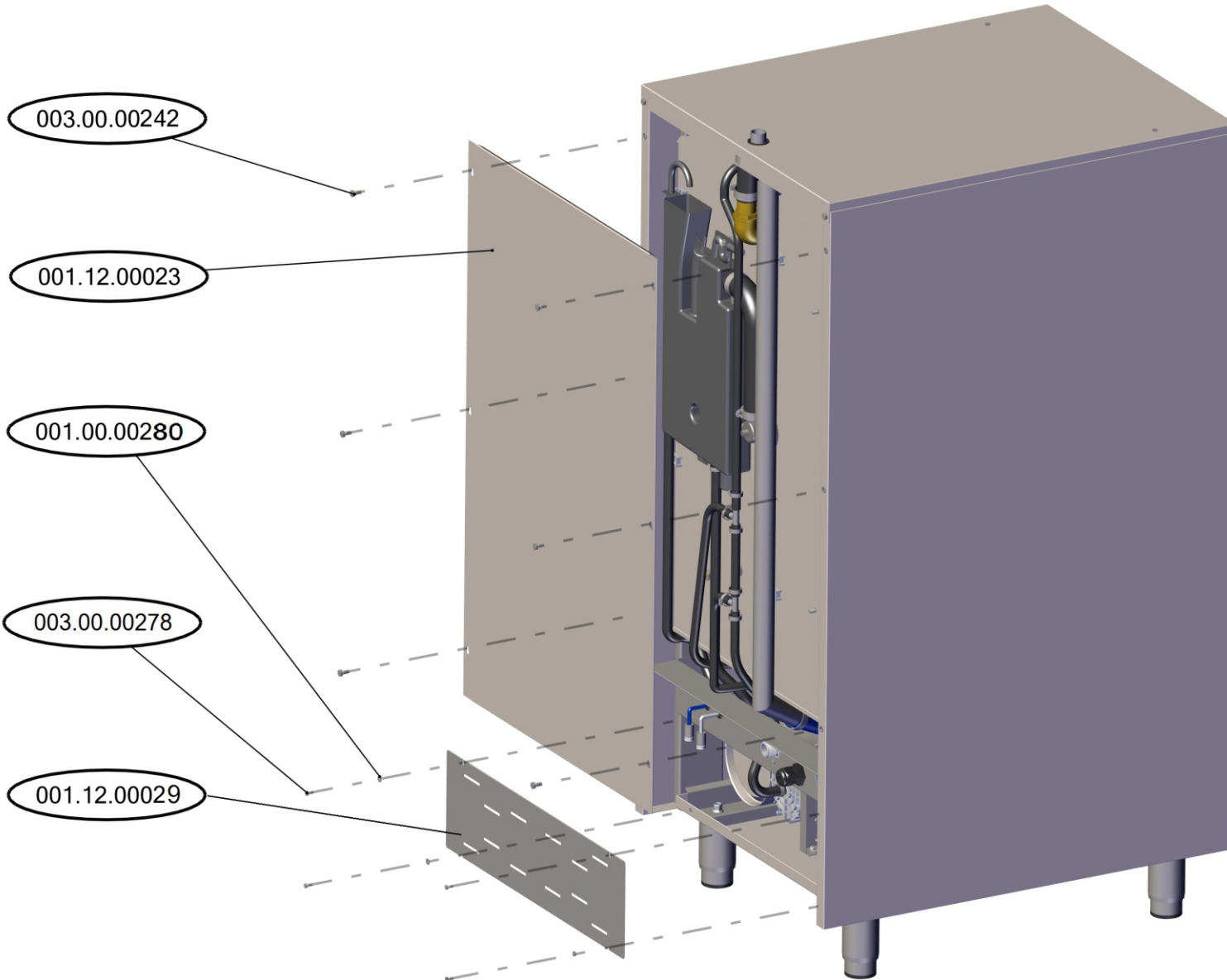

MODEL 1200

DESCRIPTION : DOOR SUPPORT - DOOR ASSEMBLY

ITEM CODE : -

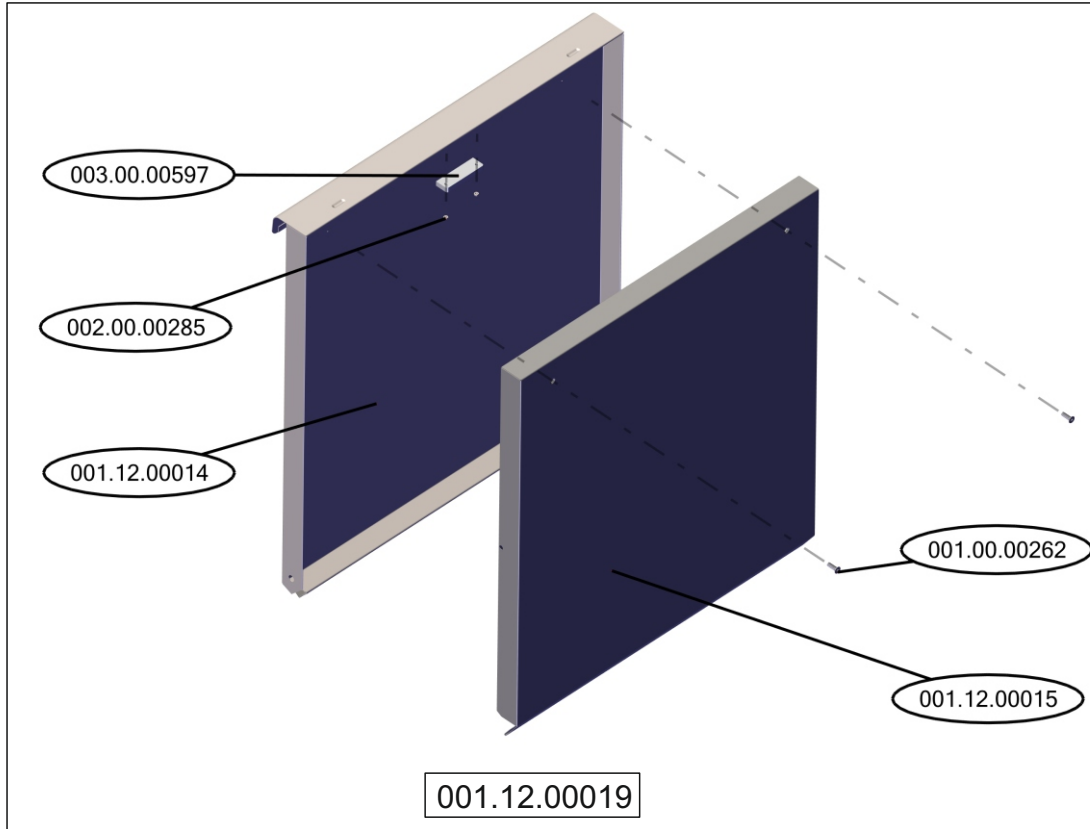

PART ID	DESCRIPTION	QTY
001.12.00014	DOOR - EXTERNAL PART	1
001.12.00015	DOOR - INTERNAL PART	1
001.00.00262	INOX TAPPERD SCREW M5X16	2
002.00.00285	INOX NUT M3	2
003.00.00597	MAGNETIC UNIT	1
001.00.00110	DOMED CAP NUT M6	2
001.00.00192	DOOR SUPPORT AXLE M6X420 Dx-Sx	1+1
001.00.00073	INOX SCREW 2.9x10	2
001.00.00221	PLASTIC GUIDE FOR DOOR AXLE	2
001.60.00035	DOOR SUPPORT Φ 9-M6 E600	2
003.00.00642	INOX TAPPERD SCREW M6X10	2

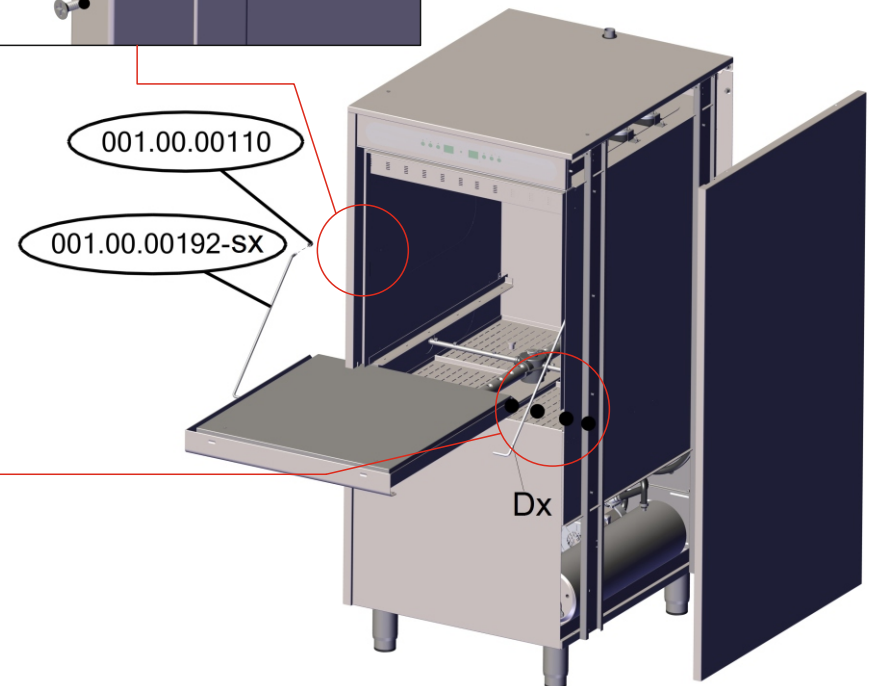
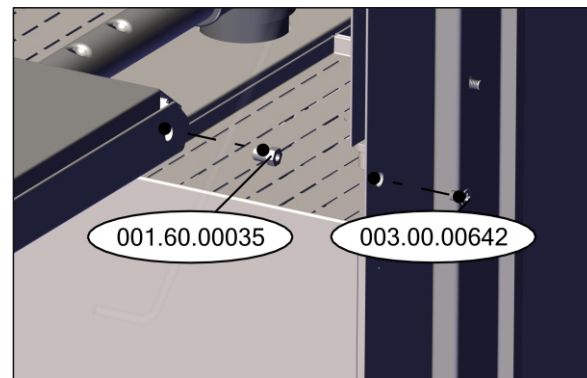
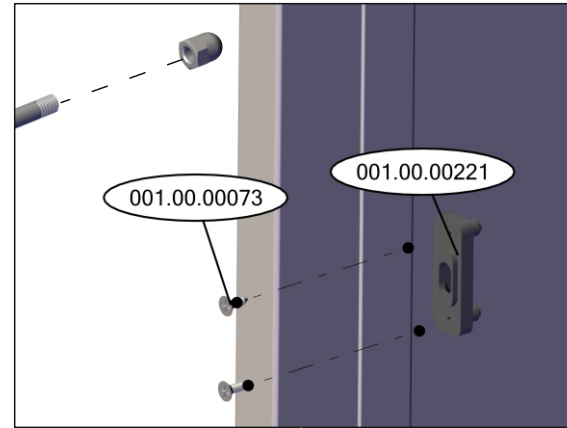

MODEL 1200

DESCRIPTION : ELECTROMECHANICAL EQUIPMENT -TOP

ITEM CODE : -

PART ID	DESCRIPTION	QTY
003.12.00004	CONTROL PANEL - COMPLETE	1
003.00.00580	MACHINE SCREW M4x10 mm (CONTROL PANEL SUPPORT)	2
003.00.00041	NUT M6 (CONTROL PANEL SUPPORT)	2
006.12.00000	ELECTRICAL BOX MODEL 1200	1
001.00.00045	TEFLON WASHER Φ 12,5 X 8 X 2,5	4
003.00.00041	NUT M6 (ELECTRICAL BOX SUPPORT)	4
003.12.00002	TOP COVER SPACER	4
001.00.00097	INOX TAPPERD SCREW M5X25	4
001.12.00048	INOX PIPE D34x50 (STEAM RELEASE)	1
002.00.00314	PRESSURE PIPE 35-45 MODEL 1200	1
002.00.00048	CLAMP 35-50	2
002.00.00123	RUBBER SHEET - 1200	2
003.00.00033	PRESSOSTAT SWITCH	2
001.35.00028	PRESSOSTAT SUPPORT	2
003.00.00200	TAPPING SCREW 3,5x9,5 GALV	2
003.00.00046	NUT M4 GALV	2
002.00.00119-1200-1	WASHING MACHINE HOSE BLACK 10X16,5 L : 1150mm	1
002.00.00047	CLAMP 12-22	2

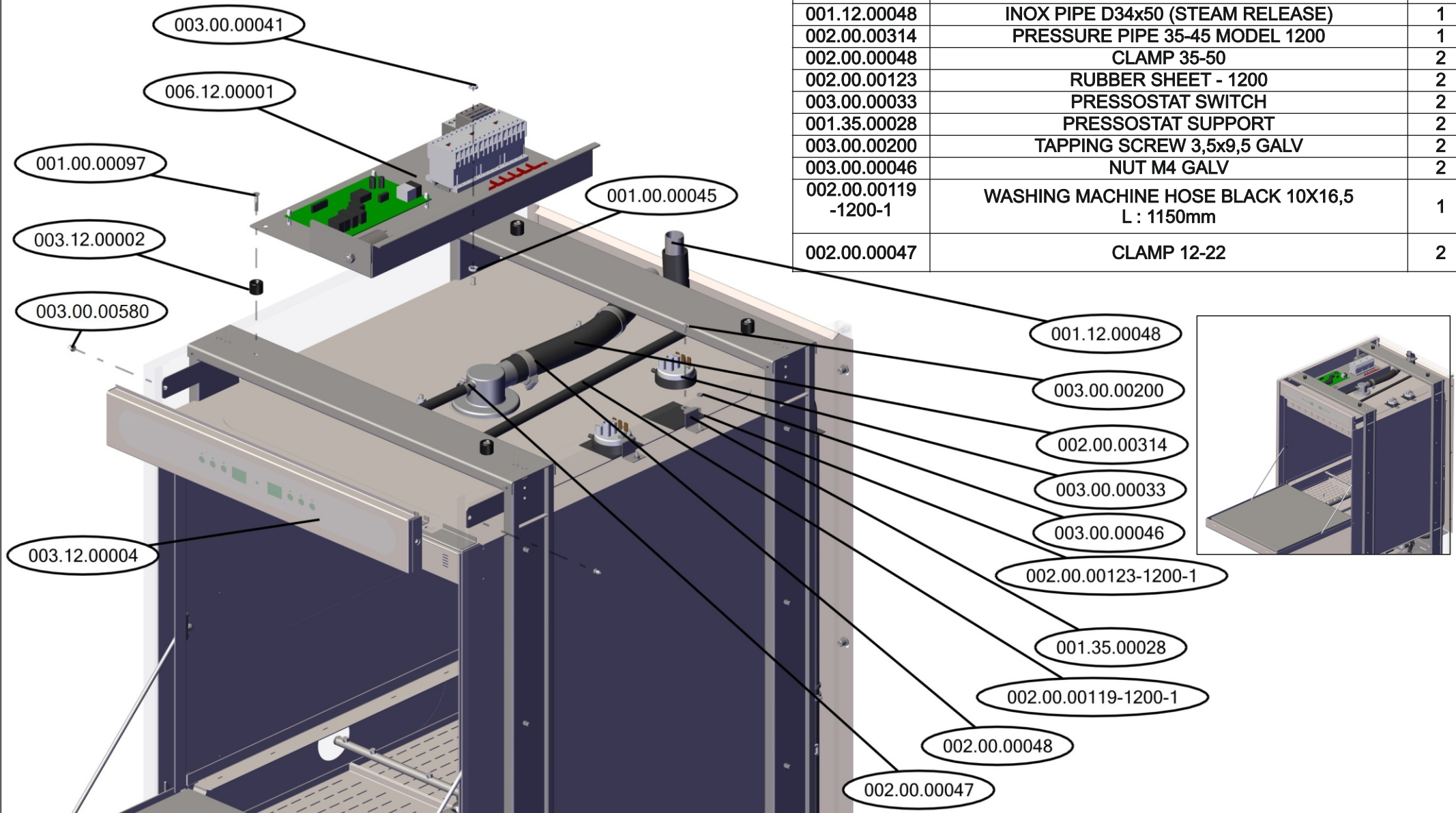

MODEL 1200

DESCRIPTION : ELECTRICAL BOX

ITEM CODE : 006.12.00001

PART ID	DESCRIPTION	QTY
001.12.00031	INOX BASE FOR ELECTRICAL BOX	1
003.12.00005	ELECTRICAL BOX COVER MODEL1200	1
003.00.00030	POWER SUPPLY BOARD 6con.	1
002.00.00046	NUT M6 GALVANISED	3
003.00.00607	ATLAS MAIN BOARD VERSION	1
003.00.00630	SPACER PLASTIC PCB RC-14	4
003.00.00625	ELECTROMAGNETIC FILTER 250V 50/60Hz	1
003.00.00301	NUT M8 GALV	1
003.00.00056	MAGNETIC CONTACTOR MINI (1NO)	3
003.00.00193	THERMAL OVERLOAD RELAY 4,0-6,0	1
003.12.00003	MAIN WIRING SET A1200 NED (NOT VISIBLE)	1
003.00.00587	THERMOCOUPLE SENSOR NTC 1.5M (NOT VISIBLE)	2

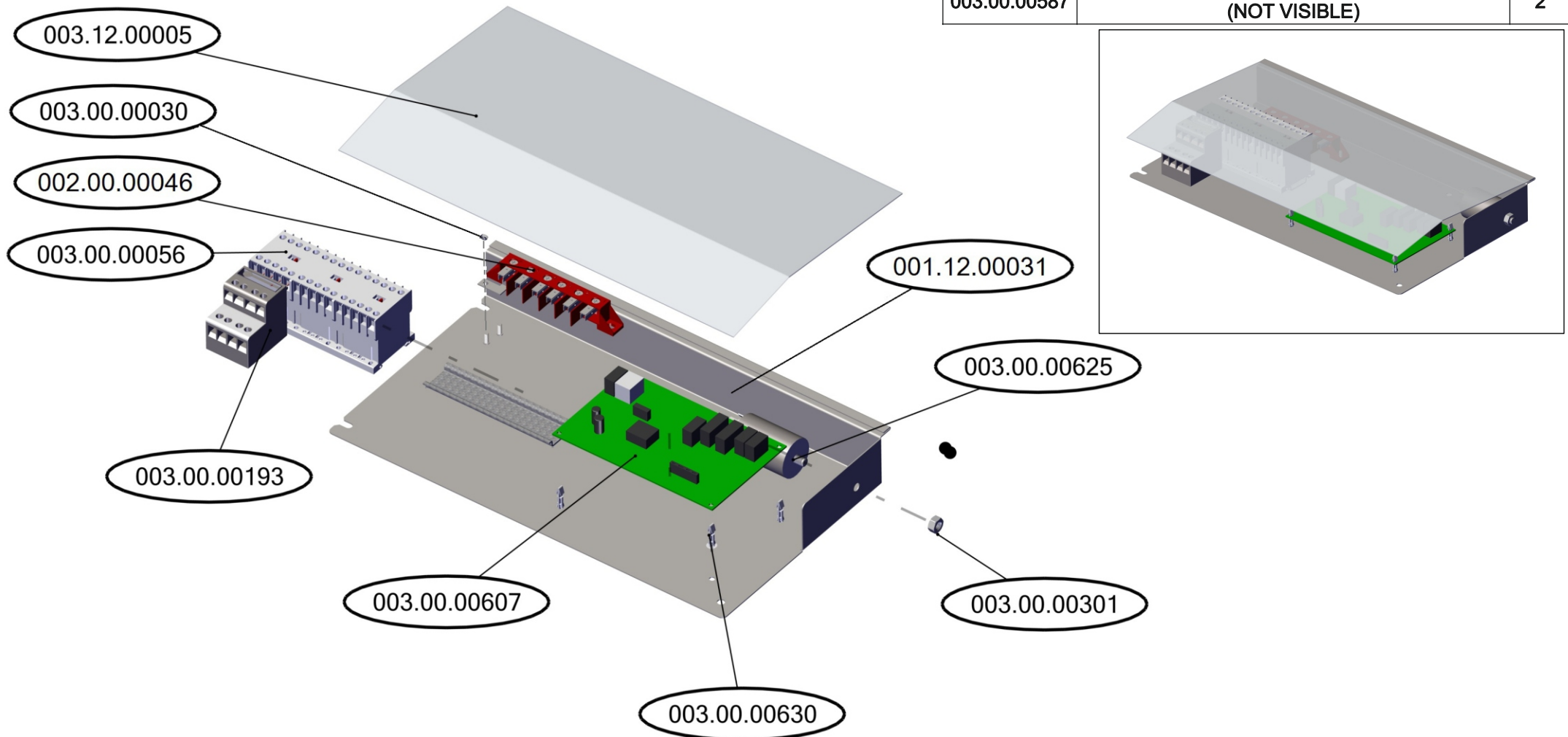

MODEL 1200

DESCRIPTION : CONTROL PANEL MODEL 1200

ITEM CODE : 003.12.00004

PART ID	DESCRIPTION	QTY
001.12.00027	CONTROL PANEL - STEEL BASE	1
003.12.00000	FILM FOR A1200 (LCD)	1
003.00.00609	USER INTERFACE 7 SEGM. DISPLAY VERSION	1
003.00.00659	PCU SPACER 3.4x6x5	4
003.00.00598	MAGNETIC SENSOR	1
002.00.00090	NUT M3 GALV	6

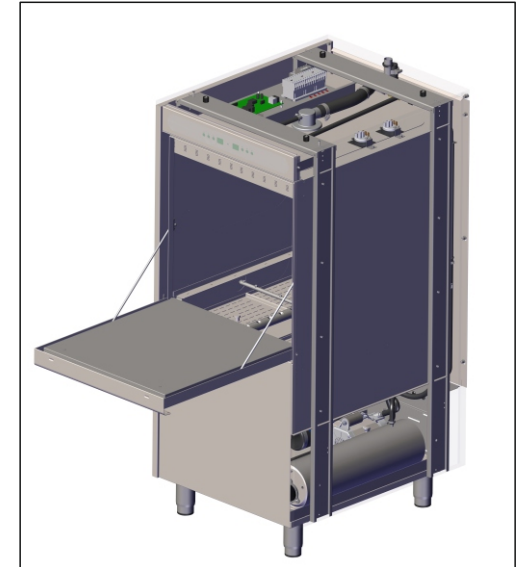
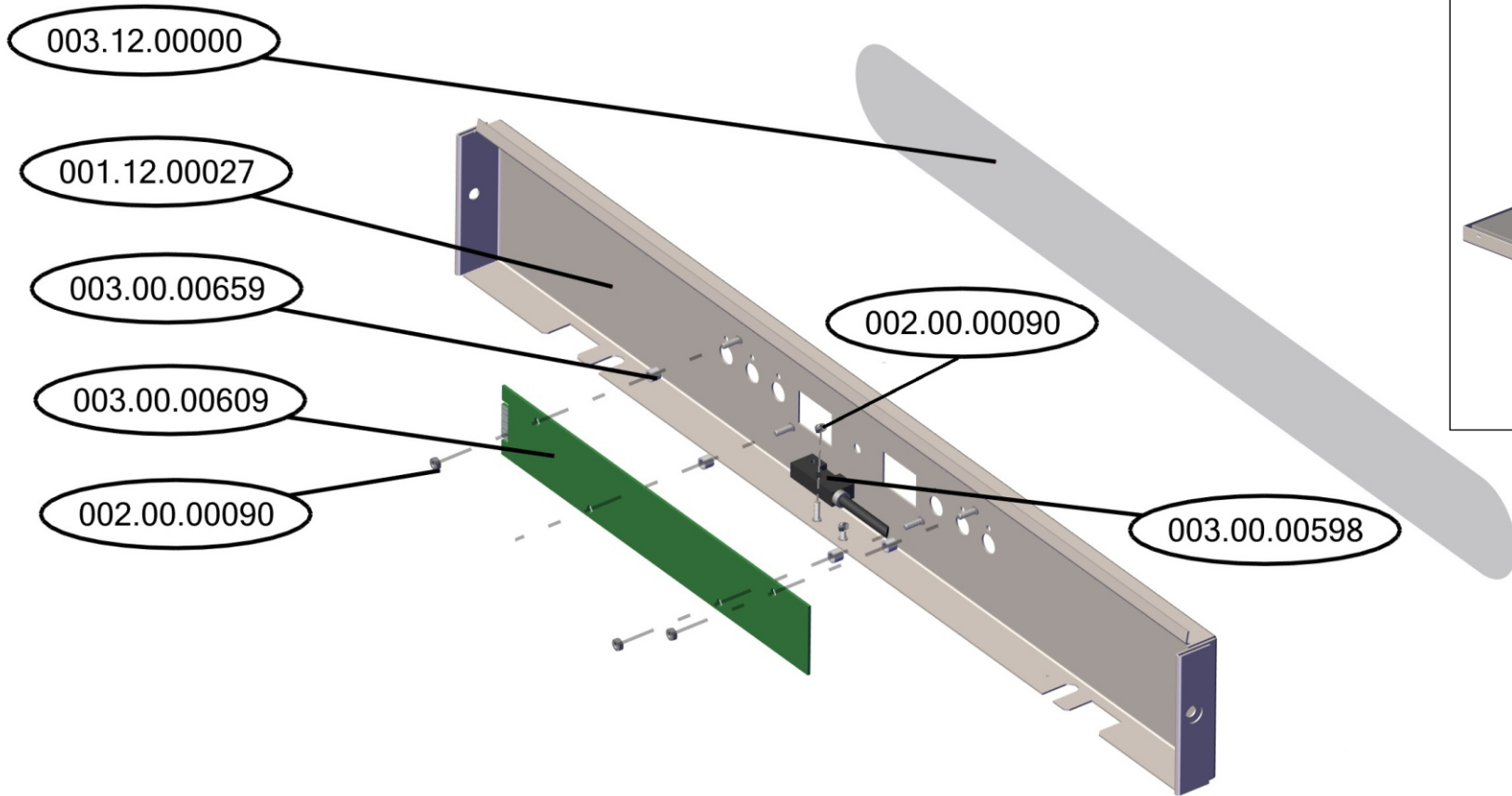

MODEL 1200

DESCRIPTION : ELECTROMECHANICAL EQUIPMENT - BACK

ITEM CODE : -

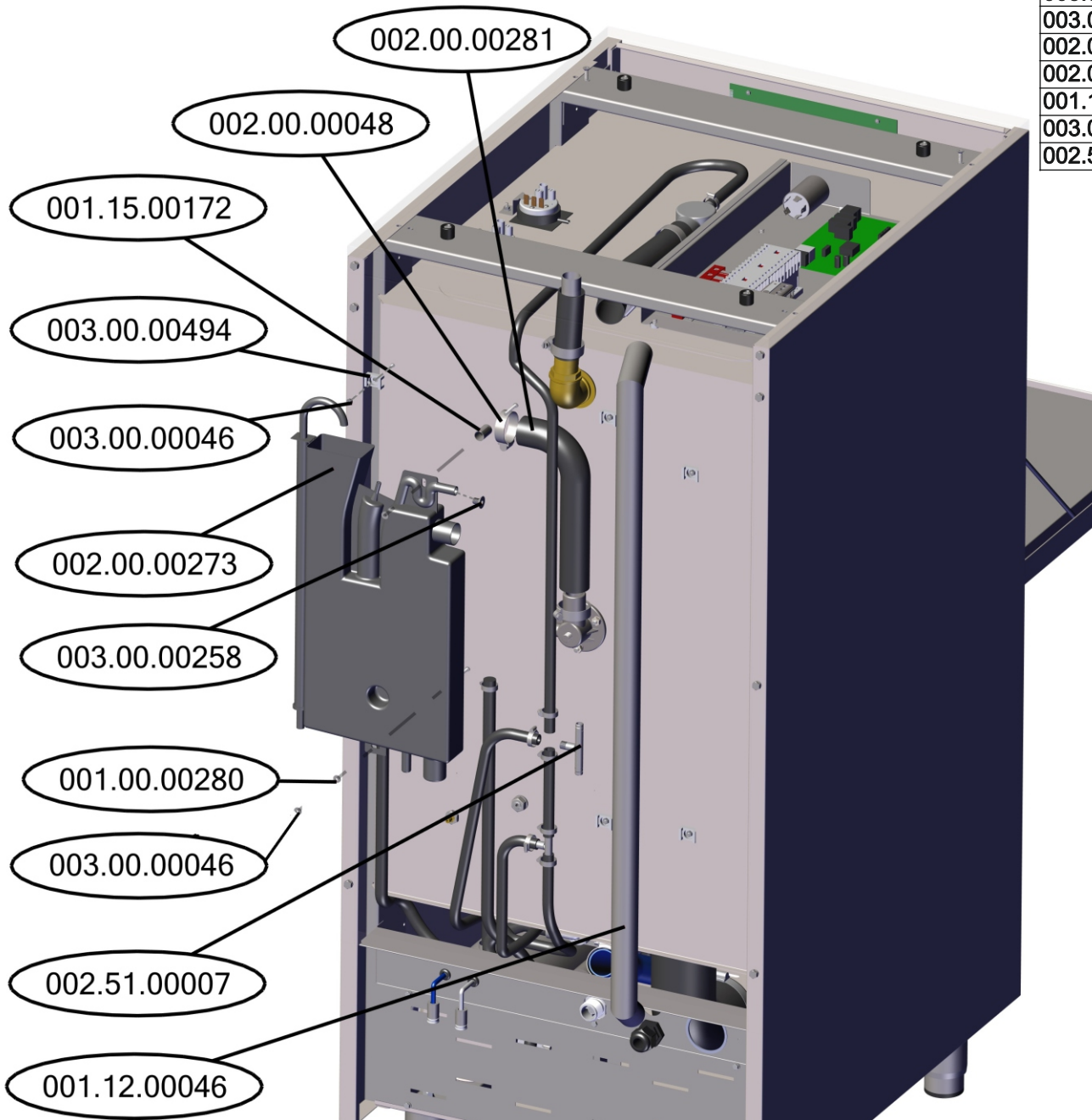

PART ID	DESCRIPTION	QTY
002.00.00273	BREAK TANK ASSEMBLY 2,4Lt	1
001.15.00172	INOX HOOD SPACER 1500 Φ12/10X23	2
001.00.00280	WASHER INOX Φ4X10	2
003.00.00046	NUT M4 GALV	8
003.00.00258	INOX SCREW M8x12 ALLEN	1
002.00.00281	ELBOW HOSE Φ38-Φ30 210X130	1
002.00.00048	CLAMP 25-40	2
001.12.00046	WASH SUPPLY INOX MODEL1200	1
003.00.00494	CABLE PLASTIC CLAMP	6
002.51.00007	T-CONNECTION	2

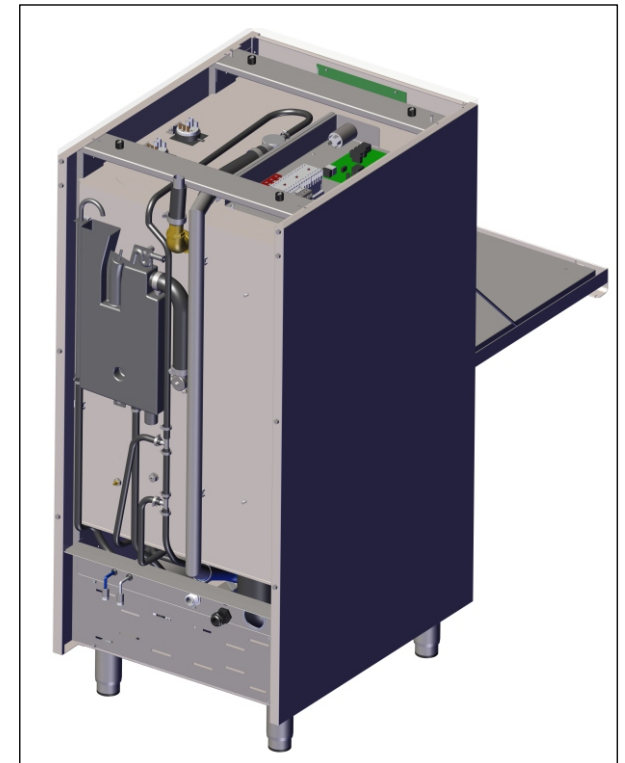

MODEL 1200

DESCRIPTION : ELECTROMECHANICAL EQUIPMENT - TOP - BACK

ITEM CODE : -

PART ID	DESCRIPTION	QTY
002.12.00001	UPPER WASH BASE 1200	1
002.12.00003	O-RING 6225 OR 160 NBR	1
002.12.00002	PLASTIC NUT FOR UPPER BASE 1200	1
002.12.00004	INOX AXLE FOR UPPER BASE 1200	1
002.12.00015	WASH&RINSE CROSS A1200 COMPLETE	1
001.00.00051	DOOR SNAP SET	2
002.12.00014	NUT 1"	1
002.12.00013	WASHER D55x35	1
002.12.00012	GASKET 1"	1
002.12.00011	THREAD NIPPLE 1" L40	1
002.12.00010	HOSE NIPPLE 1" D35	1
002.12.00009	ANGLE F/F 1" D35	1
002.00.00159	O RING10X1,5	2

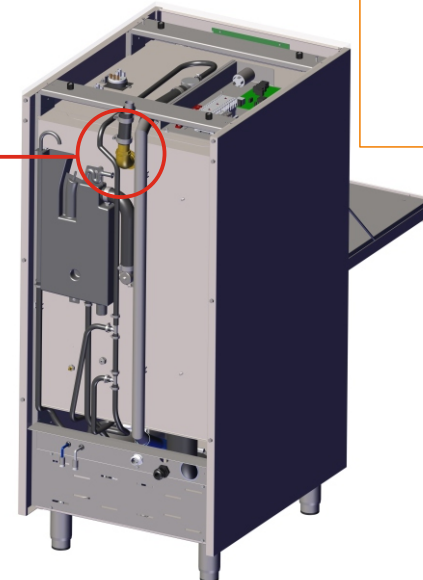
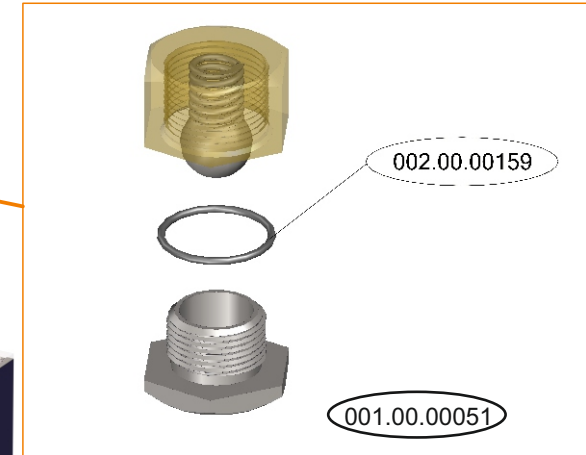
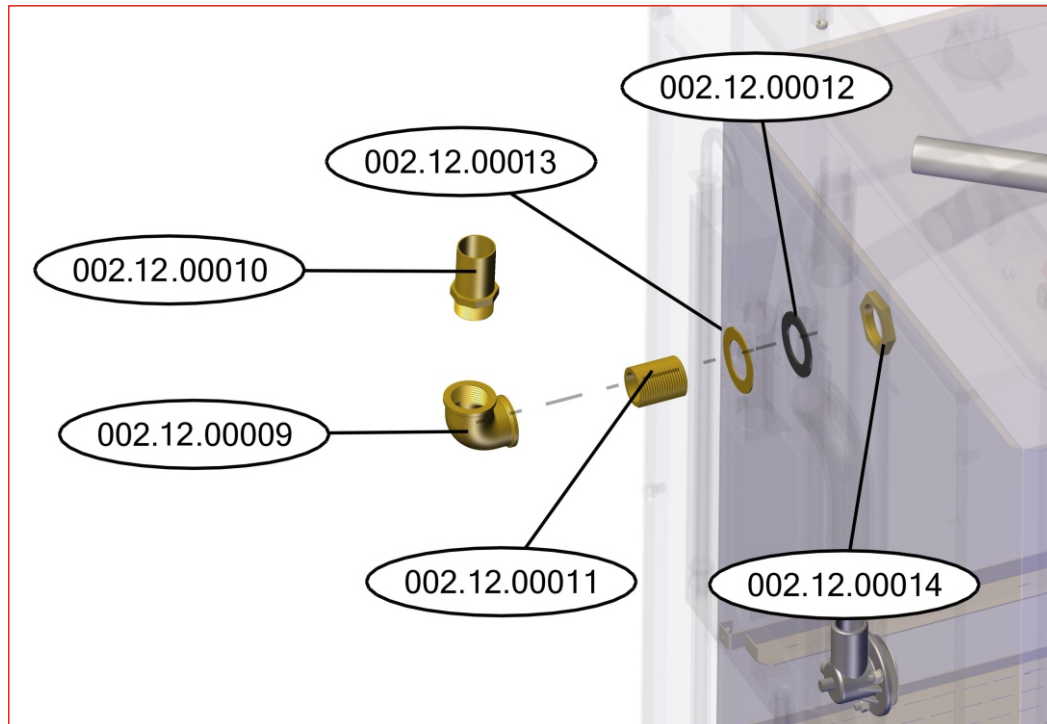
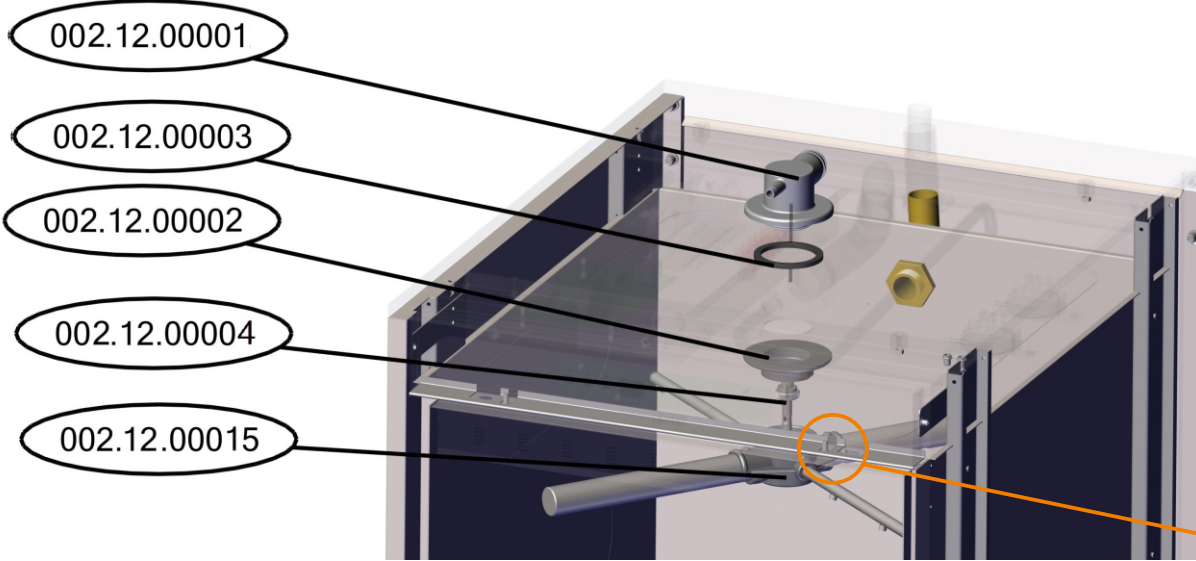

MODEL 1200

DESCRIPTION : RINSING WASHING CROSS - MODEL 1200

ITEM CODE : 002.12.00015

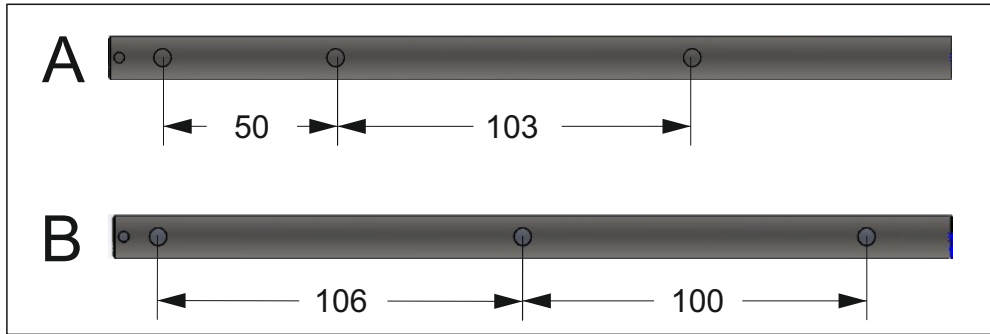

PART ID	DESCRIPTION	QTY
002.15.00085	RINSING-WASHING CROSS BASE	1
002.12.00017	INOX WASH PIPE MODEL 1200	2
003.00.00579	INOX SCREW M 4 X 10 mm	2
002.12.00016-A-B	RINSING ARM A AND B	1+1
002.00.00145	CAP FOR RINSE ARM	2
001.00.00073	INOX SCREW 2.9x10	2
003.00.00580	INOX MACHINE SCREW M 4 x 10 mm	2
002.35.00026	TEFLON D18x10	2
002.11.00008	SPRAYER FOR RINSING ARM	6

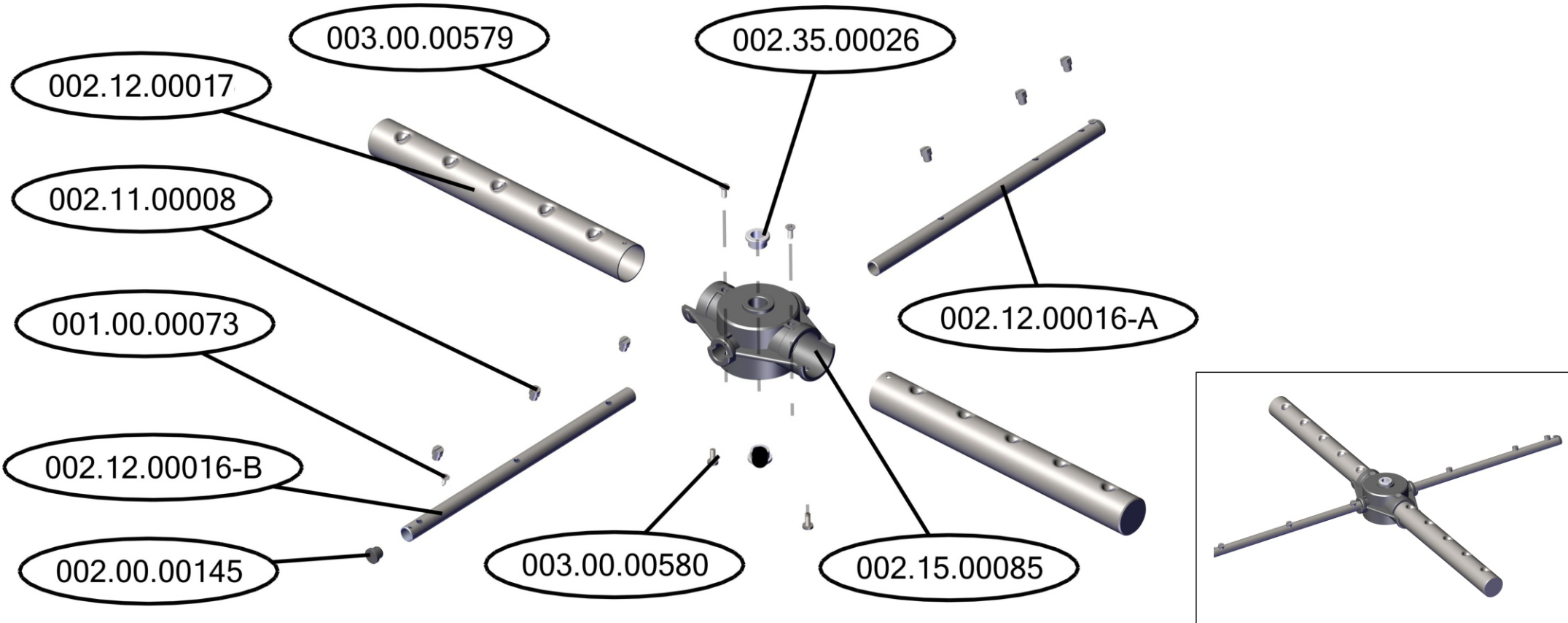

MODEL 1200

DESCRIPTION : ELECTROMECHANICAL EQUIPMENT -BACK

ITEM CODE : -

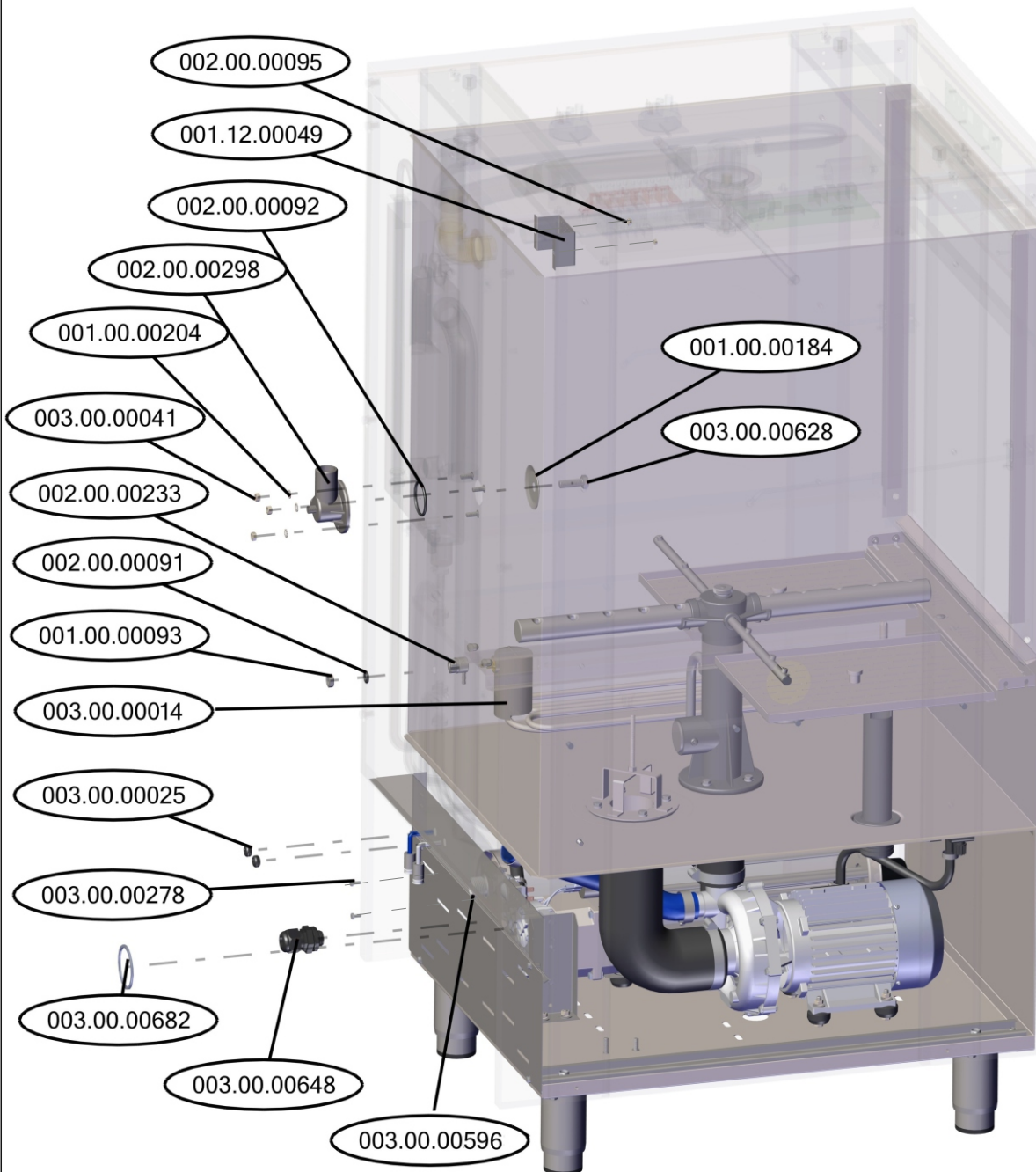

PART ID	DESCRIPTION	QTY
001.12.00049	INOX COVER FOR STEAM EXIT	1
002.00.00095	INOX M4 NUT	2
002.00.00298	PLASTIC BT BASE	1
001.00.00204	LOCK WASHER Ø6	3
003.00.00041	NUT M6 (GALV)	3
001.00.00184	INOX PLATE D58	1
003.00.00628	INOX HEX BOLT M10X30	1
002.00.00233	DETERGENT TANK INJEKTOR 4-6mm	1
003.00.00014	PRESSOSTAT CHAMBER	1
002.00.00091	O RING 3 X 10,5	1
001.00.00093	NUT M10 INOX	1
003.00.00025	CABLE RUBBER PROTECTOR	2
003.00.00596	WATER INPUT VALVE 90° (50-440V)	1
003.00.00278	GALV HEX BOLD M4X10	2
003.00.00682	PLASTIC CABLE PROTECTOR-1200	1
003.00.00648	CABLE GLAND PG 21	1

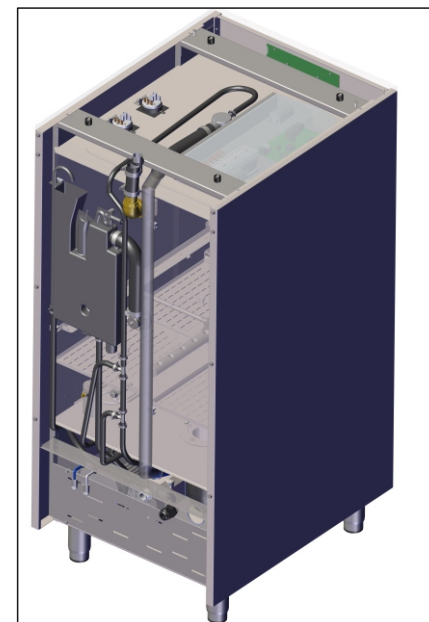

MODEL 1200

DESCRIPTION : SURFACE FILTERS

ITEM CODE : -

PART ID	DESCRIPTION	QTY
001.12.00025	FILTER SUPPORT - MIDDLE	1
001.00.00110	DOMED CAP NUT M6	2
001.00.00247	FRONT COVER SCREW INOX M6 X 25 mm	1
001.12.00024	FILTER SUPPORT - FRONT	1
002.00.00095	INOX NUT M4	2
001.12.00032	SURFACE FILTER - COMPLETE	4
001.15.00153	INOX KNOB	1/PART
003.00.00242	INOX HEX SCREW M6X12	1/PART

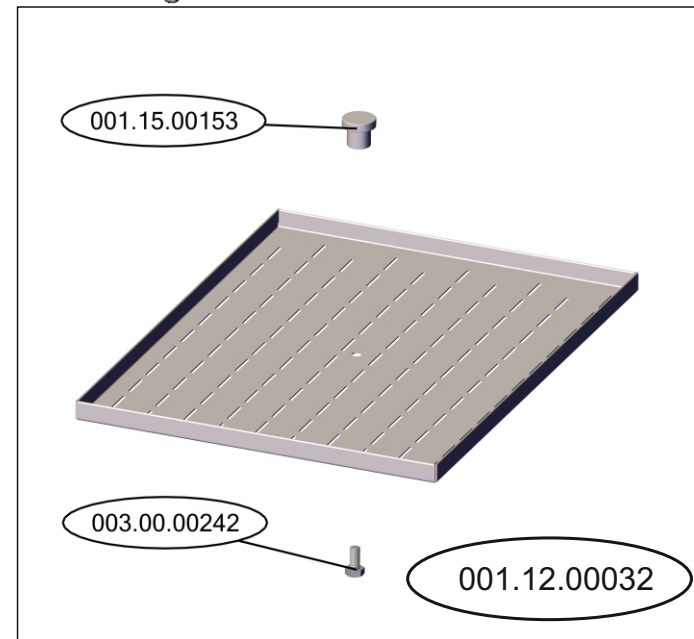
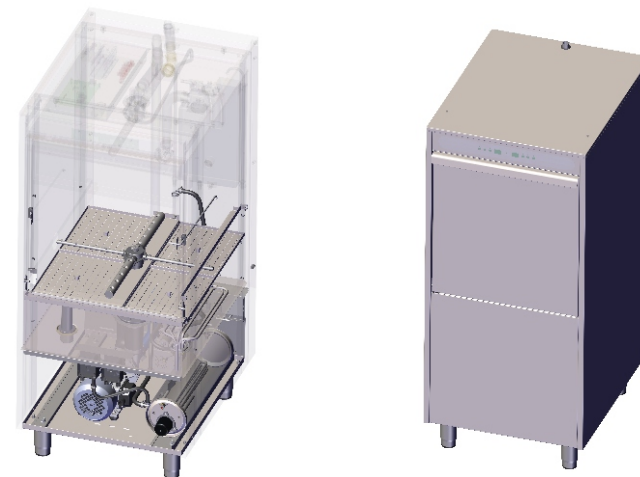
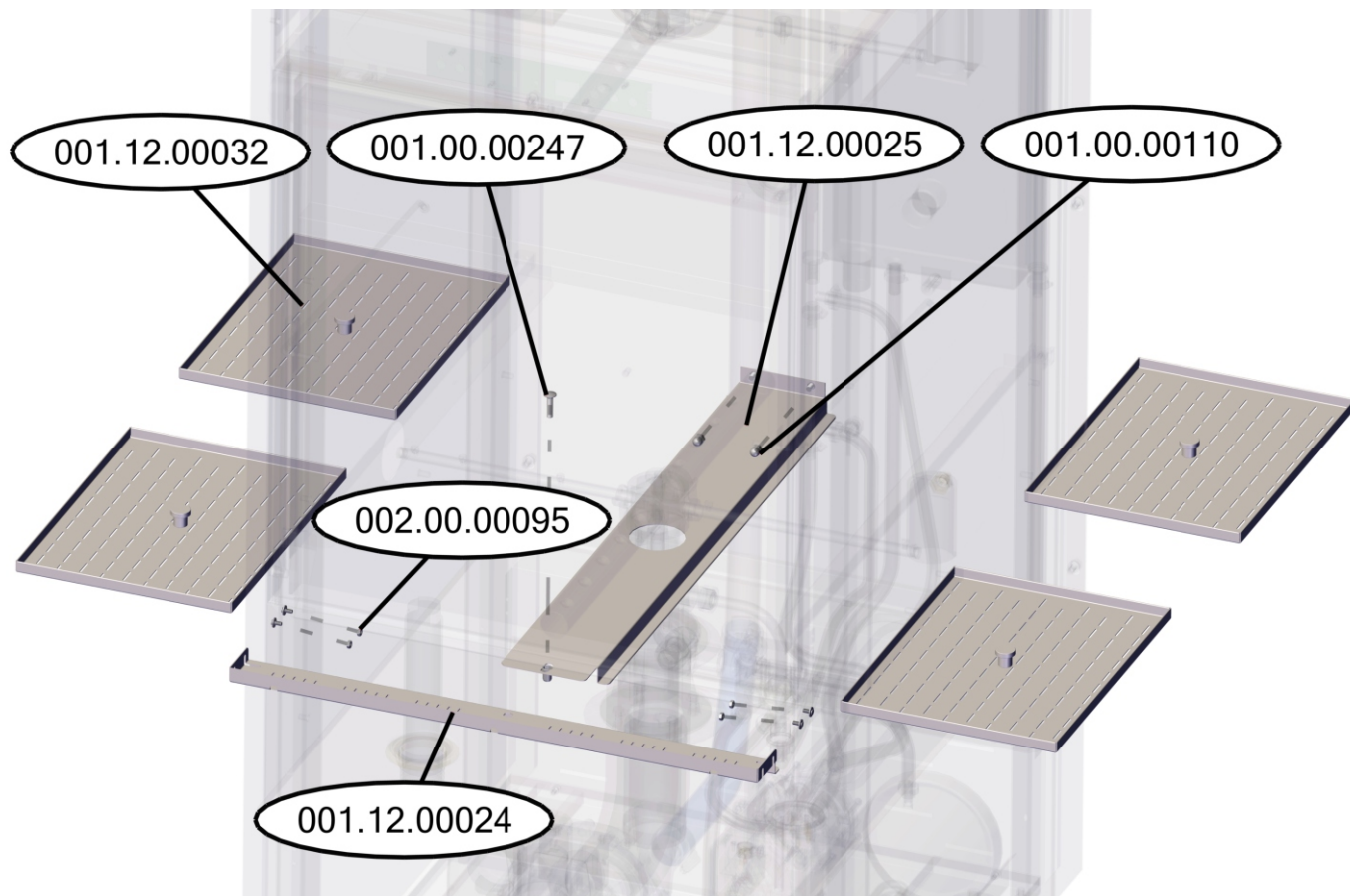

MODEL 1200

DESCRIPTION : ELECTROMECHANICAL EQUIPMENT - BOTTOM1

ITEM CODE : -

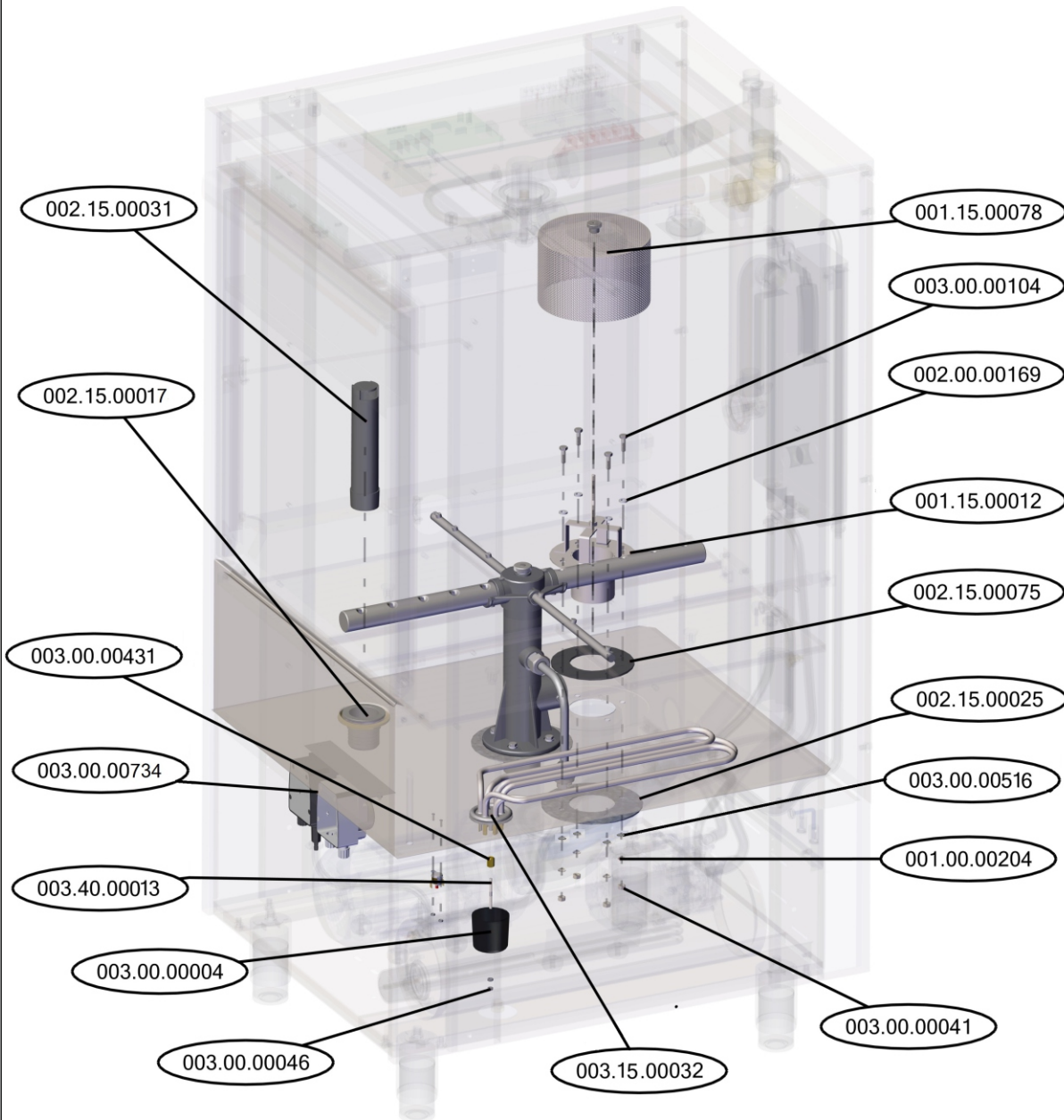

PART ID	DESCRIPTION	QTY
002.15.00031	DRAIN & OVERFLOW PIPE A 1500	1
002.15.00017	DRAIN & OVERFLOW PLASTIC BASE - COMPLETE	1
001.15.00078	PUMP FILTER TURBO 1500 - COMPLETE	1
003.00.00104	INOX HEX BOLD M6X20	4
002.00.00169	TEFLON 12-6-2	4
001.15.00012	BASE FOR TANK FILTER	1
002.15.00075	TANK FILTER BASE RUBBER GASKET	1
002.15.00025	RETAINING PLATE FOR FILTER	1
003.0.00516	WASHER GALVANISED D6x18	4
001.00.00204	LOCK WASHER D6	4
003.00.00041	NUT M6 GALVANISED	4
003.15.00032	TANK HEATING ELEMENT	1
003.00.00570	TANK HEATING ELEMENT RETAINING BRACKET	1
001.00.00204	LOCK WASHER D6	1
00M.00.00041	NUT M6 GALVANISED	1
003.00.00431	HEATING ELEMENT NUT 13mm M4 - M6	1
003.40.00013	THREADED ROD M4x45	1
003.00.00004	HEATER ELEMENT COVER	1
003.00.00046	NUT M4 GALVANISED	2
003.00.00734	DETERGENT & RINSE-AID PUMP KIT FOR MODEL	1

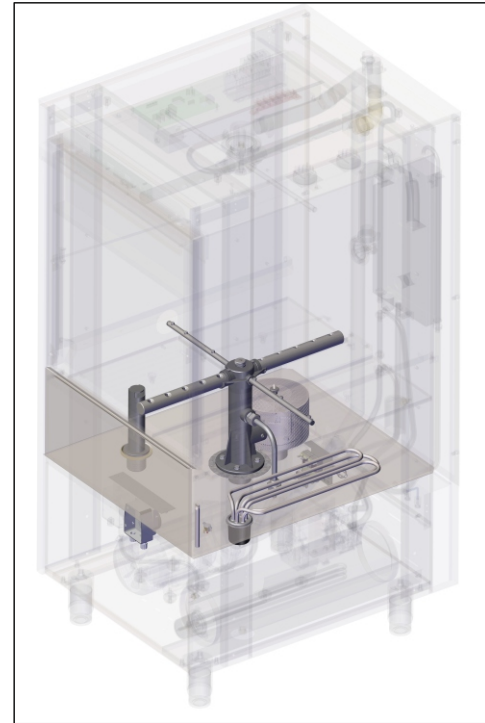

MODEL 1200

DESCRIPTION : ELECTROMECHANICAL EQUIPMENT - BOTTOM2

ITEM CODE : -

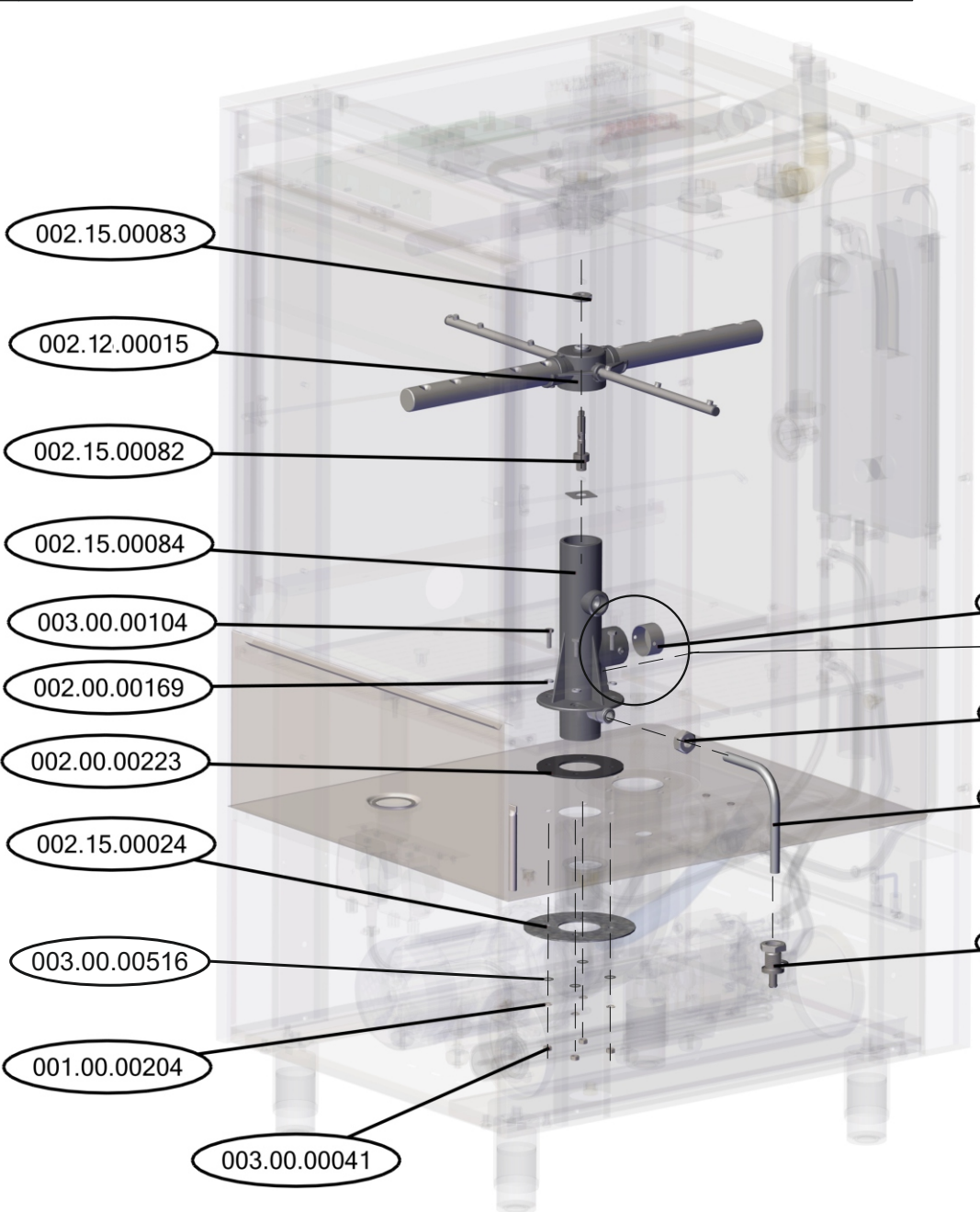

PART ID	DESCRIPTION	QTY
002.15.00083	INOX RETAINING NUT D25X7 M8	1
002.12.00015	WASH&RINSE CROSS A1200 COMPLETE	1
002.15.00082	INOX AXLE Φ20M8 TURBO 1500 EVO	1
002.15.00084	WASH - RINSE BASE TURBO 1500	1
003.00.00104	INOX HEX BOLD M6X20	4
002.00.00169	TEFLON 12-6-2	4
002.00.00223	RUBBER GASKET Φ109X54X3	1
002.00.00024	RETAINING PLATE FOR BASE 1500	1
003.00.00516	WASHER Φ6X18 GALVANISED	4
001.00.00204	LOCK WASHER D6	4
003.00.00041	NUT M6 (GALVANISED)	4
001.12.00047	BUTTOM WASH BASE PLUG	1
003.00.00441	INOX HEX BOLD M4X60	1
002.00.00140	LOCK WASHER INOX Φ4	1
002.00.00295	INOX NUT M4	1
002.00.00144	RINSE PIPE RETAINING NUT	1
002.12.00018	RINCE PIPE INOX 1200	1
002.00.00083	RINSE BASE TU-KN - COMPLETE	1

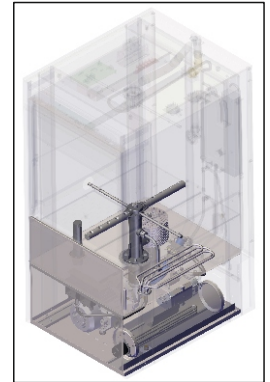
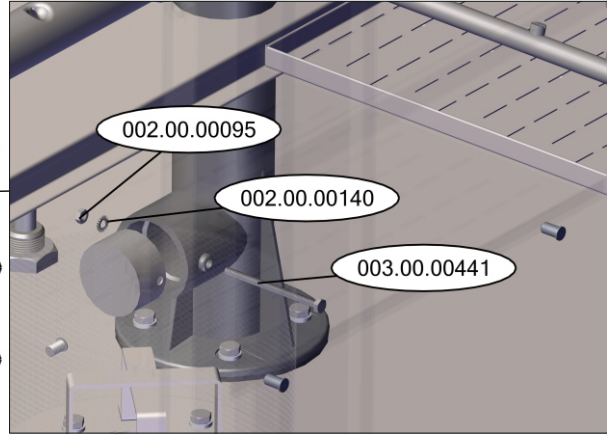

MODEL 1200

DESCRIPTION : DETERGENT AND RINSE AID PUMP KIT MODEL 1200

ITEM CODE : 003.00.00734

PART ID	DESCRIPTION	QTY
001.12.00033	BRACKET FOR PERISTALTIC PUMPS MODEL 1200	1
002.00.00195	BALANCE F15x20	2
002.00.00242	FILTER PLASTIC FOR RINSE AID VALVE	2
003.00.00046	NUT GALVANISED M4	6
003.00.00140	TUBO TRANSPARENT 4x6	-
003.00.00487	TUBO PVC BLUE 4x6	-
003.00.00684	PERISTALTIC DETERGENT PUMP SEKO	1
003.00.00687	PERISTALTIC RINSE AID PUMP SEKO	1
002.00.00162	LOCK WASHER M4	6
001.00.00280	WASHER Φ 4X10	6

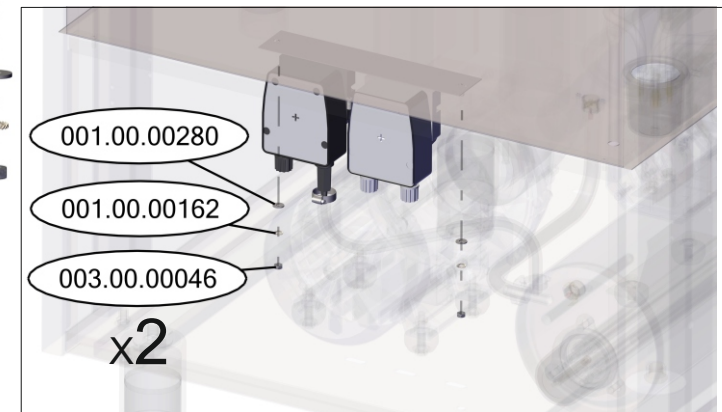
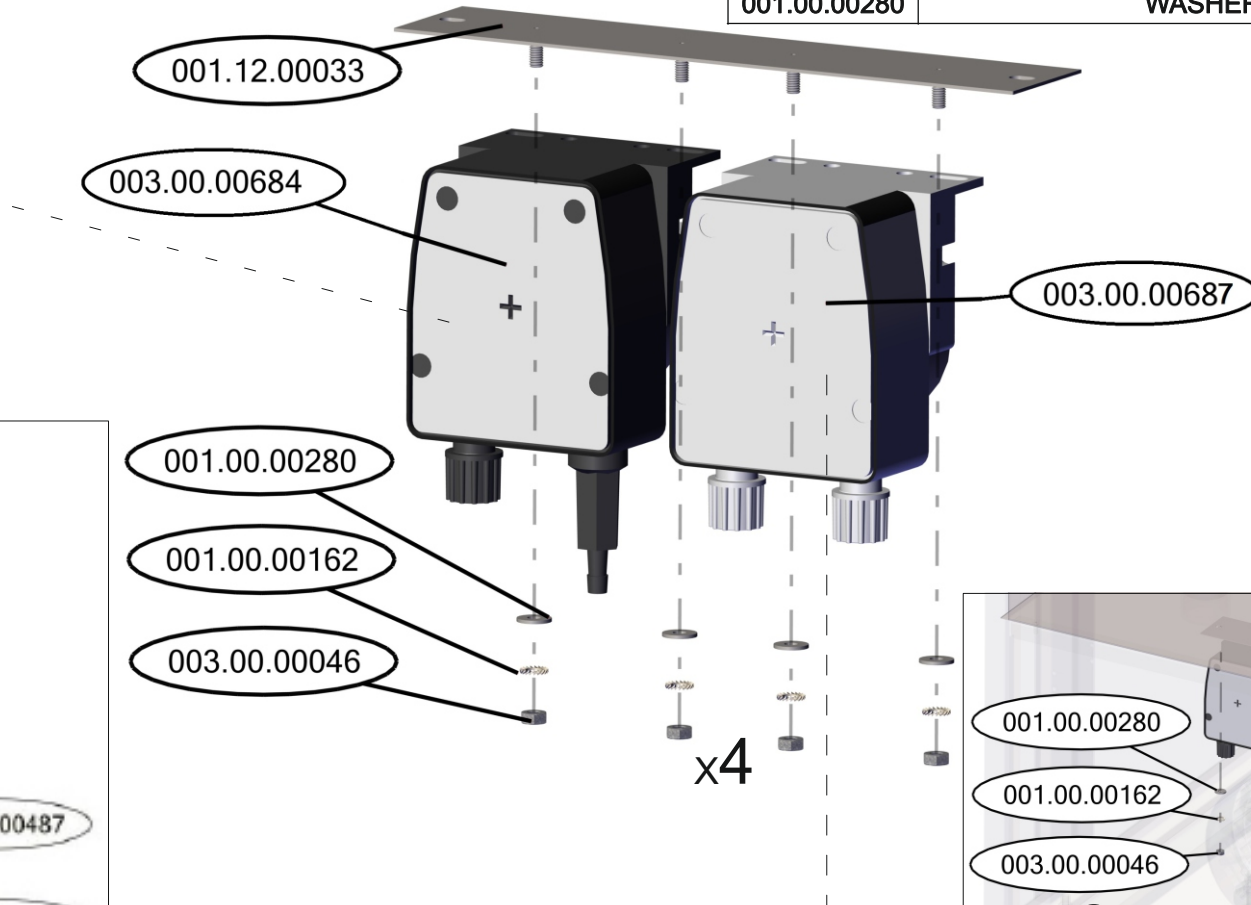
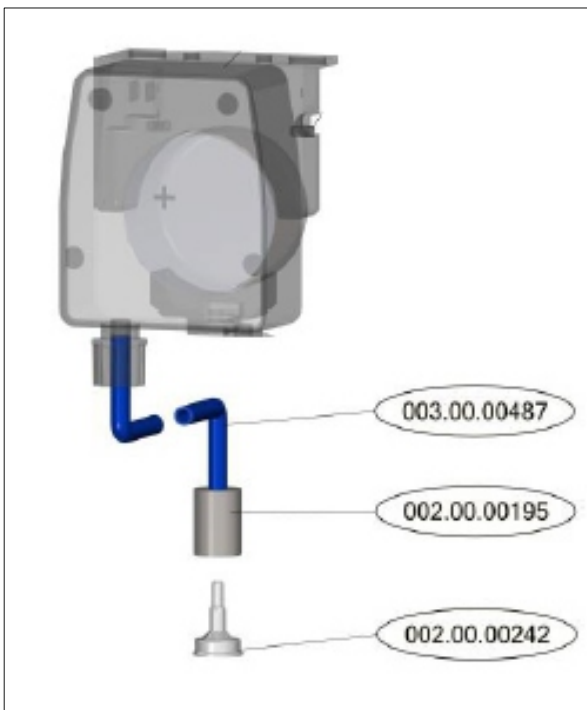
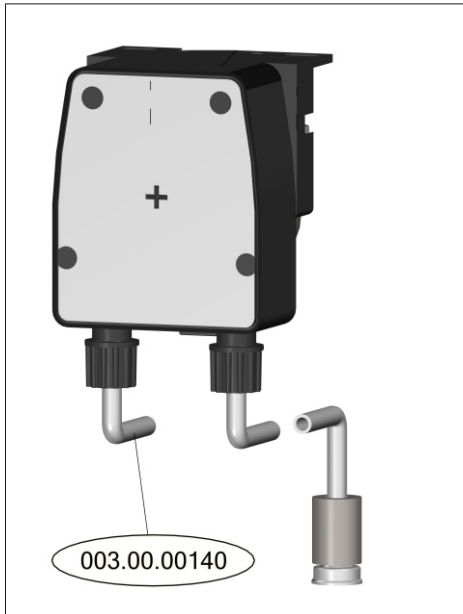

KIT SUPPORT

MODEL 1200

DESCRIPTION : ELECTROMECHANICAL EQUIPMENT - BOTTOM - BASE

ITEM CODE :

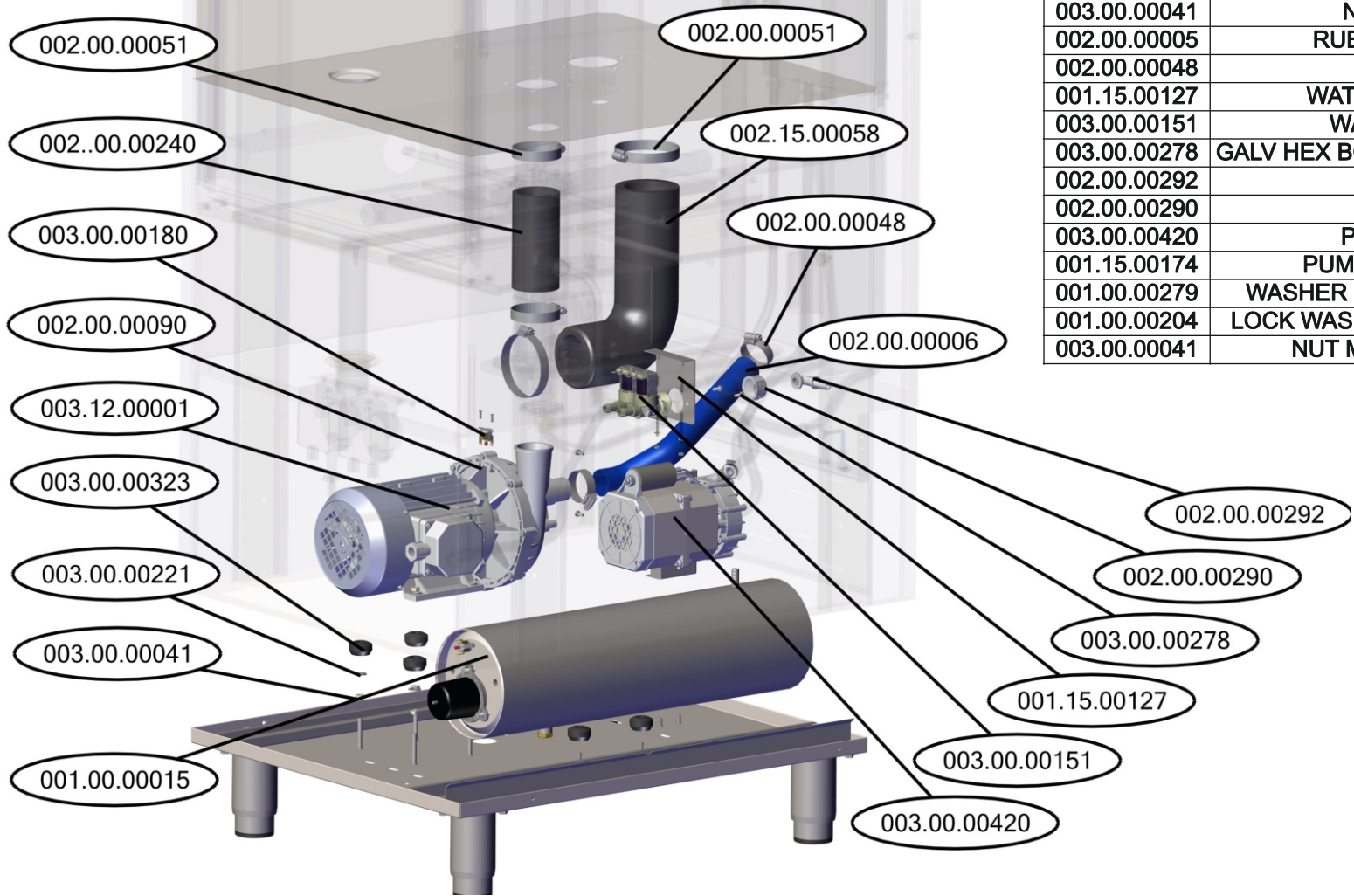

PART ID	DESCRIPTION	QTY
003.12.00001	PUMP 1,2HP-230V-50Hz	1
003.00.00323	KOPLER D8-D31 (PUMP SUPPORT)	4
003.00.00221	WASHER INOX D6X18 (PUMP SUPPORT)	8
003.00.00041	NUT M6 (PUMP SUPPORT)	8
002.00.00240	PUMP HOSE 51x61 - 1200	1
002.15.00058	PUMP INLET HOSE - 1200	1
002.00.00051	CLAMP 60-80	4
003.00.00180	THERMOFUSE BOILER 105°C	1
002.00.00090	NUT M3	2
006.15.00013	BOILER 230V SF 6KW (A1200 230/400)	1
003.00.00323	KOPLER D8-D31 (BOILER SUPPORT)	2
003.00.00221	WASHER Ø6X18 (BOILER SUPPORT)	2
001.00.00204	LOCK WASHER D6 (BOILER SUPPORT)	2
003.00.00041	NUT M6 (BOILER SUPPORT)	2
002.00.00005	RUBBER HOSE FLEXIBLE 32X325	1
002.00.00048	CLAMP 25-40	2
001.15.00127	WATER VALVE SUPPORT - SINGLE	1
003.00.00151	WATER INPUT VALVE DOUBLE	1
003.00.00278	GALV HEX BOLD M4X10 (WATER VALVE SUPPORT)	2
002.00.00292	NIPPLE INPUT - ANGLE	1
002.00.00290	FITTING 3/4"	1
003.00.00420	PUMP BOOSTER 230V/50Hz	1
001.15.00174	PUMP BOOSTER STEEL SUPPORT	1
001.00.00279	WASHER D8x16 (PUMP BOOSTER SUPPORT)	2
001.00.00204	LOCK WASHER D6 (PUMP BOOSTER SUPPORT)	2
003.00.00041	NUT M6 (PUMP BOOSTER SUPPORT)	2

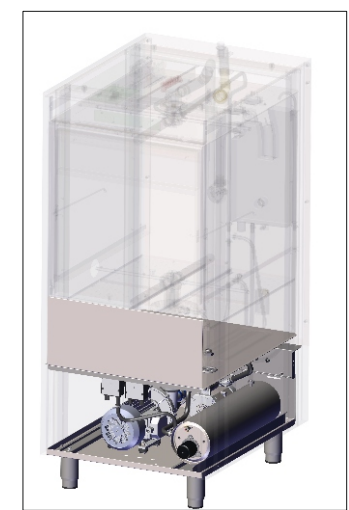

MODEL 1200

DESCRIPTION : EQUIPMENT

ITEM CODE : -



002.00.00109



001.00.00016

PART ID	DESCRIPTION	QTY
001.00.00016	FOOT SMALL M10 (MACHINE DELIVERED WITH THESE FOOT)	4
002.00.00109	INLET HOSE 1500mm - MOD40	1
001.00.00250	LEVELING FEET 1"3/4 304 120/170 M10X25	4
003.00.00727	PLASTIC BASKET (XL) 500X600 FOR TRAY	1
003.00.00728	PLASTIC BASKET (XL) 500X600 FOR CUPS	1

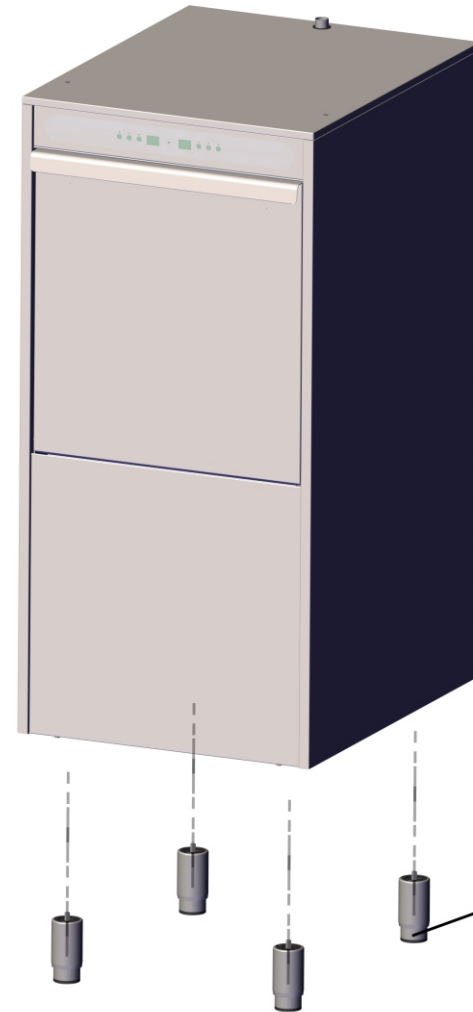

001.50.00250

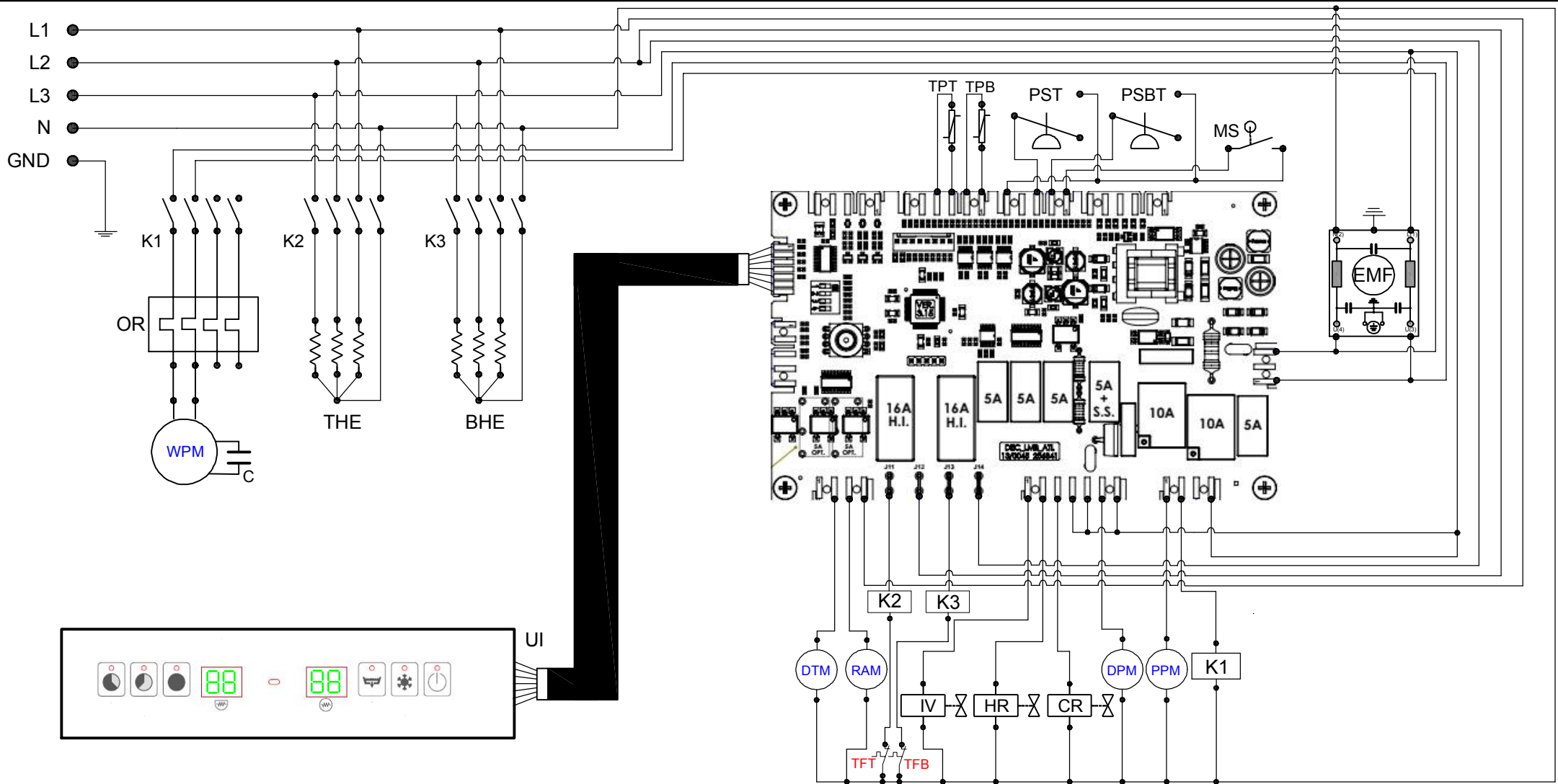

**ELECTRICAL DIAGRAM
MODEL GL 1200**

Power Supply

380 - 415 V ~ 3 N 50 / 60 Hz

- | | |
|--------------------------------|------------------------------|
| EMF : Electromagnetic filter | TFB : Thermofuse Boiler |
| UI : Users interface | TFT : Thermofuse Tank |
| MS : Magnetic switch | IV : Inlet Valve |
| PST : Pressostat Tank | HRV : Hot Rinse Valve |
| PSBT : Pressostat Break Tank | CRV : Cold Rinse Valve |
| TPB : Thermo Probe Boiler | PPM : Pressure Pump Motor |
| TPT : Thermo Probe Tank | DPM : Drain Pump Motor |
| DTM : Detergent Pump Motor | BHE : Boiler Heating element |
| RAM : Rinse Aid Pump Motor | THE : Tank Heating Element |
| K1,K2,K3 : Magnetic Contactors | WPM : Washing Pump Motor |
| OR : Overload Relay | C : Capacitor |